



NoxTech Project Status Update

Biogas Technology Advisory Committee
Working Group Meeting
Wednesday, October 29, 2014

Mark E. Iverson, P.E.
Director of Maintenance

NoxTech at the Mills Pump Station



NoxTech at Temecula Valley RWRF



NoxTech at Temecula Valley RWRF



Site Differences

- TVRWRF Similar to Woodville and Mills Installations
 - » Two Lean Burn Engines (530 HP Each)

- Digester Gas Similar to Landfill Gas
 - » Low BTU
 - » High Moisture Content

- Blend Use of Digester Gas and Natural Gas
 - » Digester Gas Production Varies

- Digester Gas added at Burner and Add Fuel
 - » Needed in Natural Gas Use

NOxTech Process

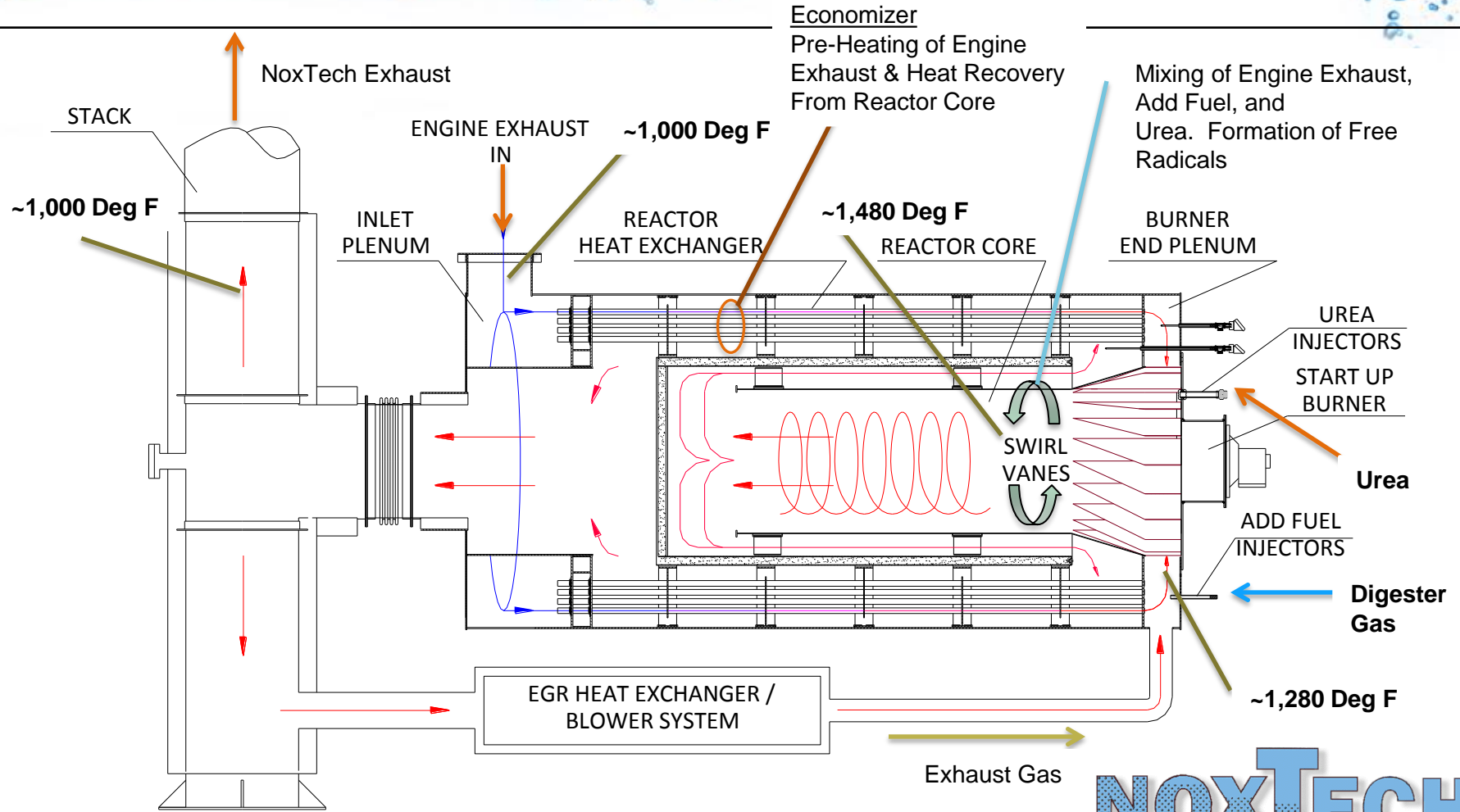

NOXTech

TVRWRF NoxTech - Digester Gas Results

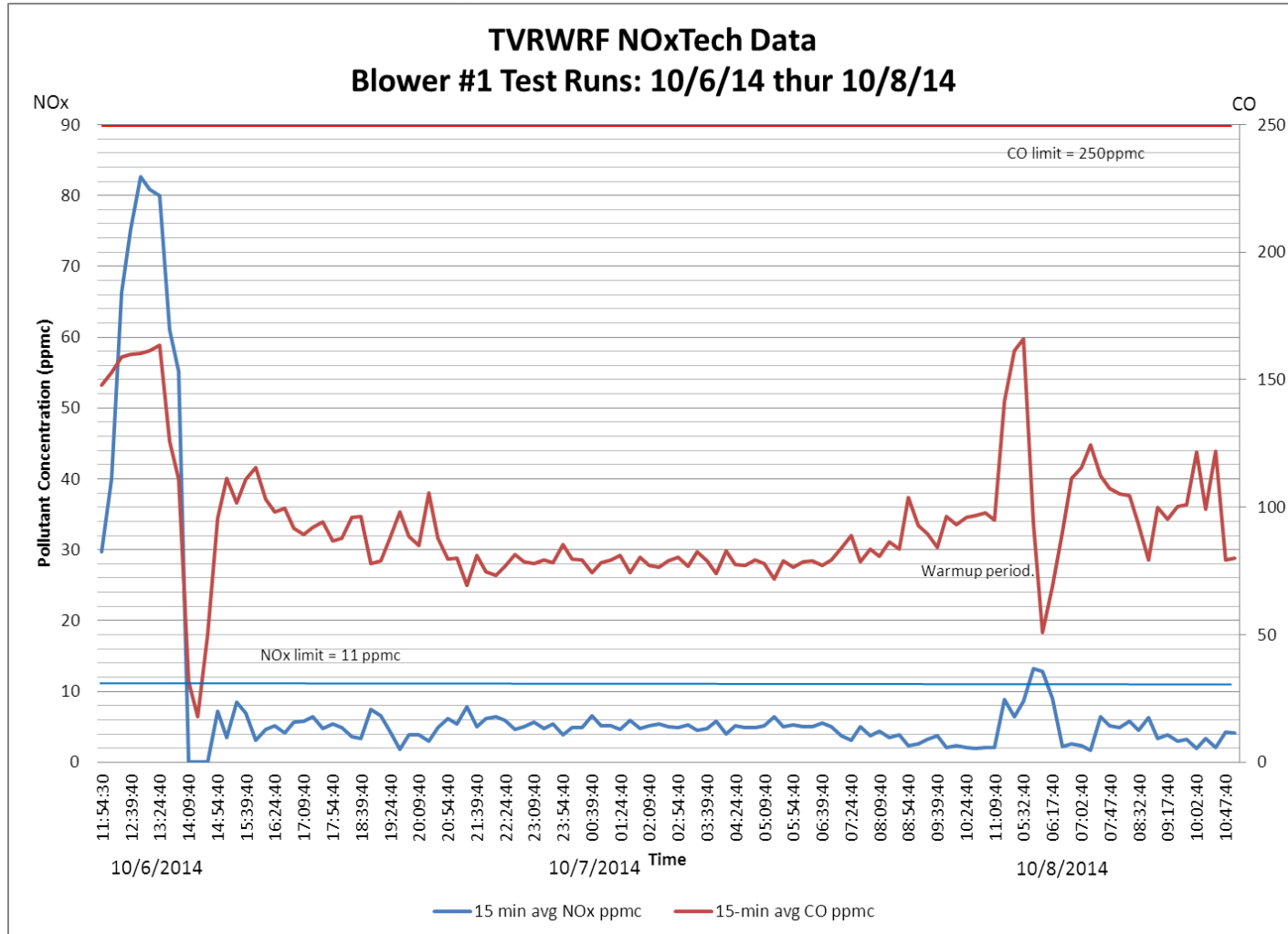

TVRWRF NoxTech Testing Results Oct 21 Through 26 2014

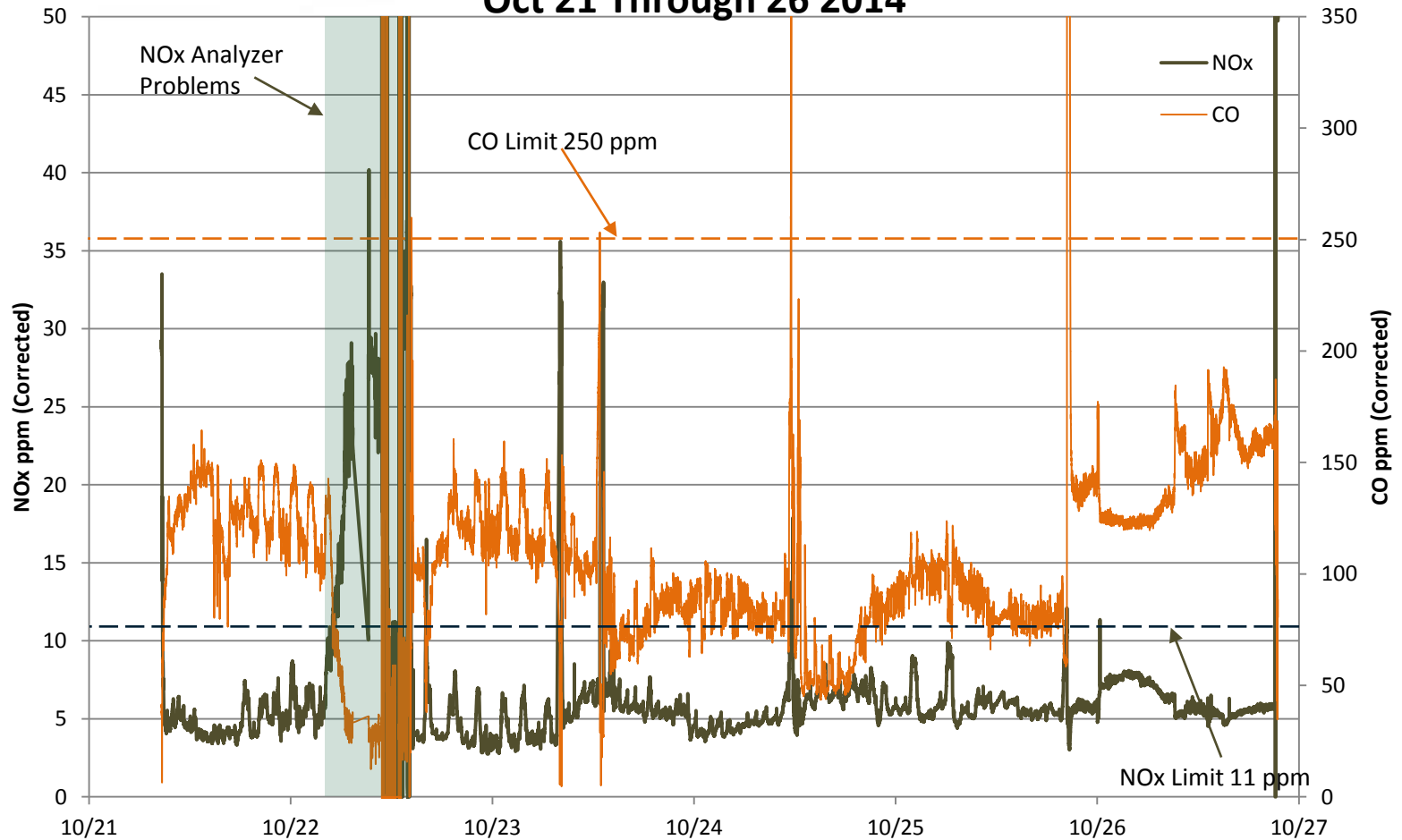

TVRWRF NoxTech Testing Results Oct 25 2014

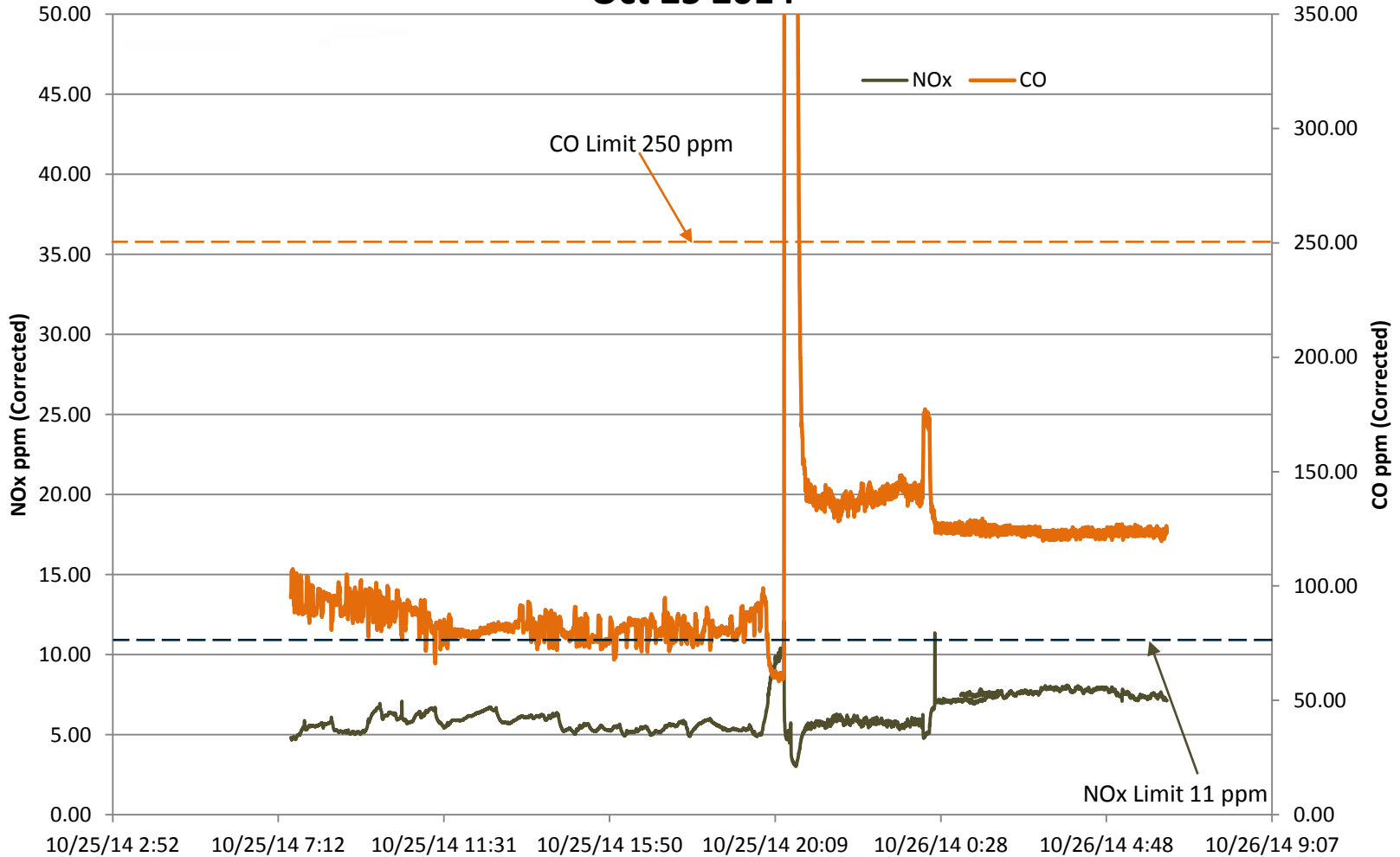

Site Differences

- Start-Up
 - » Time to Meet Emission Requirement

- Transitions of Fuel Blends
 - » Emission Excursions During Fuel Blend Changes

- Siloxane Exhaust Build-up
 - » Possible Plugging of Continuous Monitors

Site Differences

TVRWRF NoxTech

- | | |
|----------------------------------|----------|
| ➤ Research and Development Stage | Oct 2014 |
| ➤ Pilot Demonstration | 6 months |
| ➤ Result Evaluation | (?) |

EMWD

- Other Projects
 - » Moreno Valley RWRf Tecogen Biogas Project
 - » San Jacinto Valley RWRf Biogas



- EASTERN MUNICIPAL WATER DISTRICT

Contact Information

Mark E. Iverson, P.E.
Director of Maintenance
951-928-3777 ext. 6326
iversonm@emwd.org